

THIRD WRAP INDICATOR ASSEMBLY

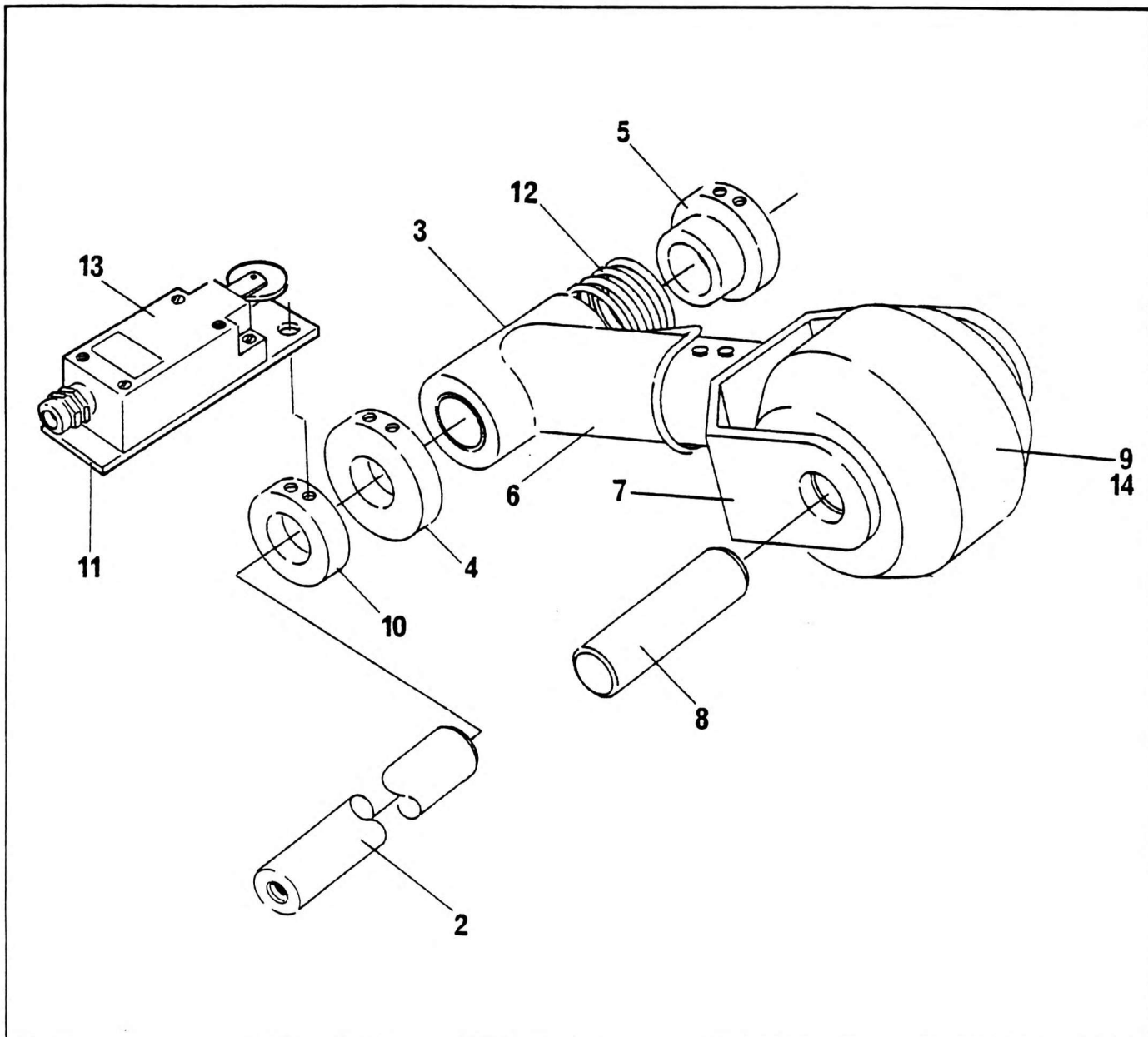

NO.	PART NO.	QTY.	DESCRIPTION	NO.	PART NO.	QTY.	DESCRIPTION
-	7-486-990262	1	Complete Assembly				
2	9-486-990227	1	Shaft				
3	9-486-990228	1	Rocker Arm				
4	9-486-990229	1	Switching Cam				
5	9-486-990230	1	Spring Clamp				
6	9-486-990231	1	Shaft				
7	9-486-990232	1	Sheave Holder				
8	9-486-990233	1	Shaft				
9	9-486-990234	1	Roller				
10	9-486-990235	1	Set Collar				
11	9-486-990236	1	Angle				
12	9-486-990237	1	Spring				
13	9-486-990238	1	Switch				
14	9-486-990239	2	Ball Bearing				

7-486-990262